

TCPM Series

Single-stage Centrifugal Pumps

PRODUCT CATALOGUE



PRODUCT OVERVIEW

Reliable & Efficient

Product Description

TCPM is a high-efficiency, single-stage centrifugal pump. It is compact in structure and easy to operate and maintain. It is suitable for both domestic and industrial applications to convey clean water and non-aggressive chemical liquids. It can be used for water supply for villas, hotels, and garden irrigation.



Material

- Pump body: Cast Iron
- Impeller: Brass (stainless steel is optional)
- Shaft: Steel (stainless steel is optional)
- Motor housing: Aluminum
- Mech seal: Ceramic/Graphite/NBR

Operating Data

- Medium: clean water or non-aggressive chemical liquid (free of solids or fiber)
- Max. Liquid Temp: 80 °C
- Max. Ambient Temp: 40 °C
- Max. pressure: 10 bar
- Max. Suction: 8 m

Motor

- Insulation Class: F
- Protection Class: IPX4
- Continuously rated
- Externally ventilated
- 220-240V/60Hz

Model Description

TCPM 110 / 1.1-1-220-60-2

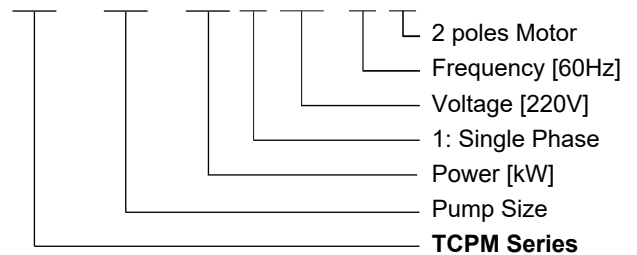

Key Features

- High-efficiency and Power-saving
- Compact in structure
- Easy to operate and maintain
- Can achieve pressure and flow with minimum losses due to the hydrodynamic closed impeller.

PERFORMANCE RANGE

Technical Data

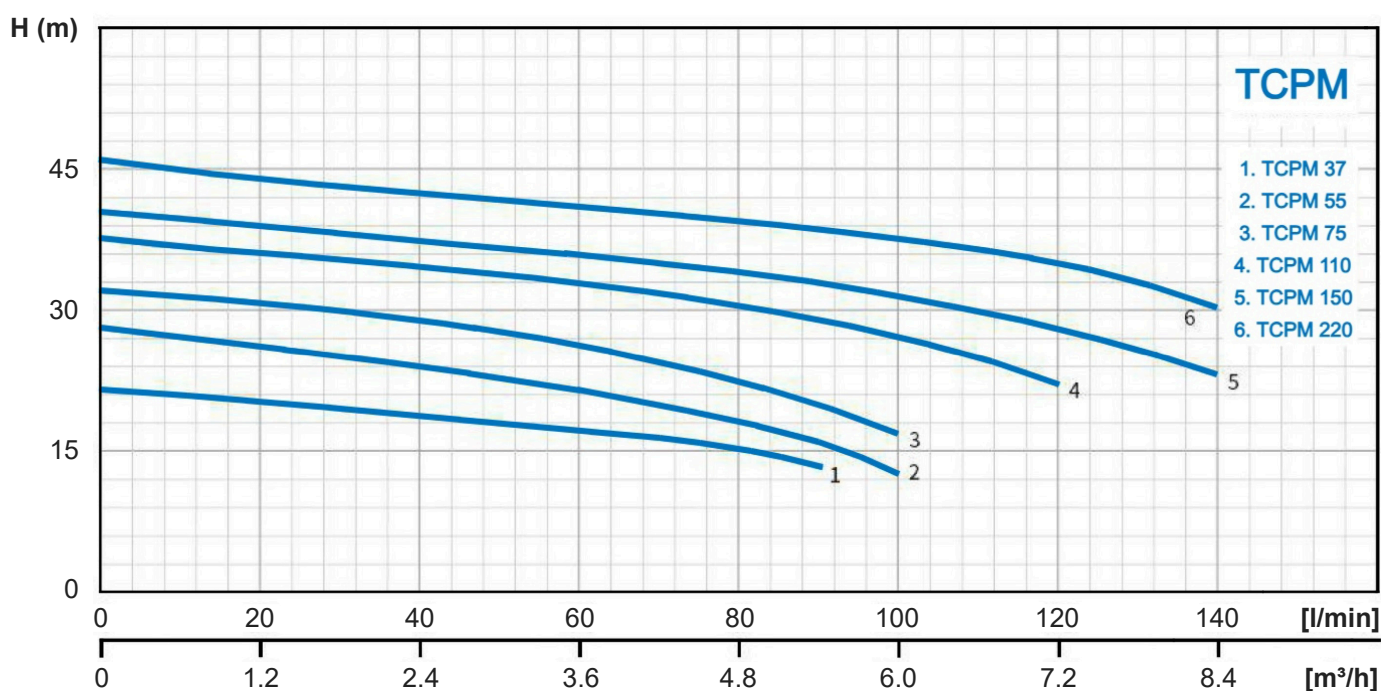

Model	Power (P2)		Max. Flow		Max. Head [m]	Max. Suct [m]	DN1/DN2	Weight [kg]
	[kW]	[hp]	[m³/h]	[L/min]				
TCPM 37	0.37	0.5	5.4	90	22	8	1" x 1"	9
TCPM 55	0.55	0.75	6.0	100	28	8	1" x 1"	11.8
TCPM 75	0.75	1.0	6.0	100	32	8	1" x 1"	13
TCPM 110	1.1	1.5	7.2	120	38	8	1" x 1"	21
TCPM 150	1.5	2.0	8.4	140	40.5	8	1" x 1"	25.5
TCPM 220	2.2	3.0	8.4	140	46	8	1" x 1"	26.5

DIMENSIONAL DRAWING

Packing Information

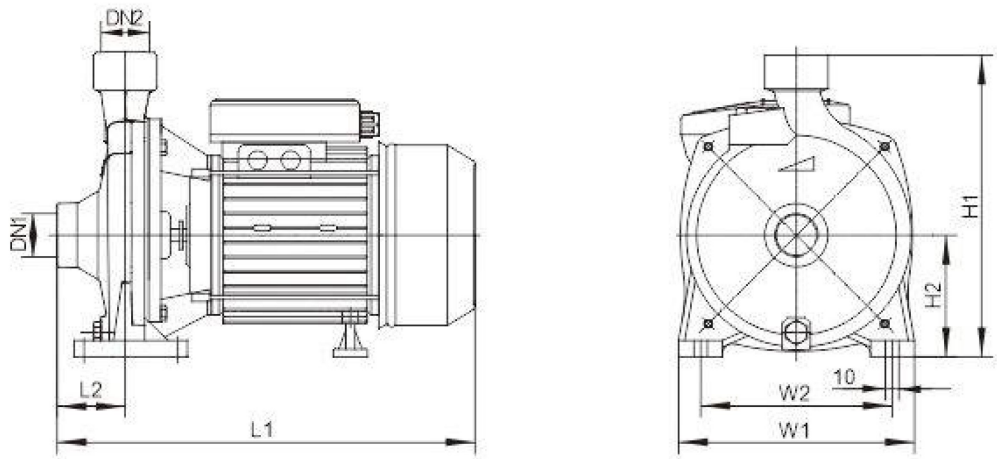

Model	DN1	DN2	Dimensions [mm]						Package Dimensions [mm]
			L1	L2	W1	W2	H1	H2	
TCPM 37	1"	1"	270	44.5	170	135	220	88	280x185x240
TCPM 55	1"	1"	294	47.5	175	142	225	90	310x195x250
TCPM 75	1"	1"	303	42.5	190	167	243	98	315x220x265
TCPM 110	1"	1"	358	55	215	180	276	110	365x235x300
TCPM 150	1"	1"	358	55	230	200	300	120	365x255x330
TCPM 220	1"	1"	358	55	230	200	300	120	365x255x330

TECNODYNE

TECNODYNE PUMPS INC.

02 Sheppard Ave E, North York
Ontario, Canada M2N 5Y7
T: +1 (647) 255-2270
info@tecnodyne.ca
www.tecnodyne.ca

TECNODYNE (China) Ltd.

Suite C, Level 7, World Trust Tower
50 Stanley Street, Central
Hong Kong
hk@tecnodynepumps.com
www.tecnodynepumps.com